



MODIFIED SINE WAVE INVERTER WITH CHARGER

USER'S MANUAL

SOLAR INVERTER

PV1100 PLUS 1200VA/1800VA/2400VA

Scan QR code for manual



Appliances



PC



TV



Air-
conditioning



Fridge



Washing
machine

4200-000249-0700

General Precautions

1. Before using it, read all instructions and cautionary markings on :
(1) inverter (2) the batteries (3) this manual
2. CAUTION --To reduce risk of injury, charge only lead-acid rechargeable batteries.
If customer use flooded batteries, they must maintain them usually. Other types of batteries may cause damage and injury.
3. Do not expose it to rain, snow or liquids of any type. It is designed for indoor.
4. Do not disassemble it. Take it to a qualified service center when service or repair is required.
5. To prevent the risk of electric shock, disconnect all wiring before attempting any maintenance or cleaning. Turning off the unit will not reduce this risk.
6. WARNING: Provide ventilation to outdoors from the battery compartment. The battery enclosure should be designed to prevent accumulation and concentration of hydrogen gas at the top of the compartment.
7. NEVER charge a frozen battery and connect the inverter with 12V to 24V battery.
8. Input/output AC wiring must be no less than 18 AWG gauge copper wire and rated for 75°C or higher. Battery cables must be rated for 75°C or higher and should be no less than 6AWG gauge.
9. Be extra cautious when working with metal tools around batteries. Short-circuiting the batteries could cause an explosion.
10. Read the battery manufacturer's installation and maintenance instructions prior to operating.

Personnel Precautions

1. Have plenty of fresh water and soap nearby in case battery acid contacts skin, clothing or eyes.
2. Avoid touching eyes while working near batteries.
3. Never smoke or allow a spark or flame in vicinity of a battery.
4. Remove personal metal items such as rings, bracelets, necklaces, and watches when working with batteries. Batteries can produce a short-circuit current high enough to make metal melt, and could cause severe burns.
5. If a remote or automatic generator start system is used, disable the automatic starting circuit or disconnect the generator to prevent accident during servicing.

FOLLOW STANDARD

EN 60950-1:2006+A2:2013+A11:2009+A1:2010+A12:2011

EN 55022:2010, EN 55024:2010, EN 61000-3-3:2008

Introduction

It is a cost effective, intelligent solar inverter which accept Solar&Utility input at the same time. The comprehensive LCD display offers user-configurable and easy-accessible button adjustment such as battery charging current, AC/solar charger priority and output source priority, When battery voltage low, it will automatically switch to AC grid to supply continuously power to the loads.

Features:

- Simulated sine wave inverter
- Built-in 50 amp solar charge controller
- 10A or 20A standard charging current from utility
- MFD (multi-function display)
- AC/solar priority for output via MFD
- AC/solar priority for charging via MFD
- Smart user friendly interface
- 3 step charging algorithm
- Overload & short-circuit protection
- Battery reverse polarity protection
- Deep discharge protection
- Auto restart while AC is recovering
- Adjustable solar and utility charging current

Product Overview

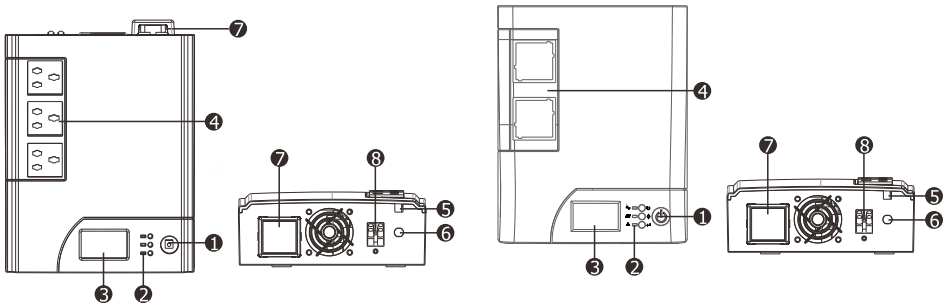

1. Power switch
2. Status indicators(please see the Operation section for the details)
3. LCD display
4. Output receptacles
5. AC input
6. Input circuit breaker(plastic case)
Input fuse(metal case)
7. External battery connectors
8. Solar panel terminal

Installation

NOTE: Before installation, please inspect the unit. Be sure that nothing inside the package is damaged.

Mounting the unit

The unit only can be mounted vertically to a wall surface.

Please follow below steps:

1. Turn off the unit before mounting.
2. Select an appropriate mounting location. Use a horizontal and the length at one must be 80mm and mark the two ends on the wall. (see right chart)
3. Drill two marks by screws.
4. Mount the unit by positioning the key-hole slots over the mounting screws.

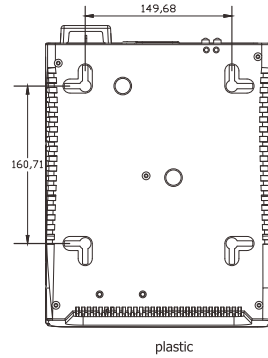

Connect to utility and charge

Plug the AC input cord to the wall outlet. The unit will automatically charge the connected external battery even though the unit is off.

Connect external battery

Step1: Away the cover of external battery terminal.

Step2: Following battery polarity guide printed near the battery terminal.

RED cable to the positive terminal (+);

BLACK cable to the negative terminal (-).

WARNING! Please use the appropriate battery cable.

Step3: Tight the battery cables with the M5 nuts .Do not place anything between the flat part of battery terminal and the battery cable ring terminal or overheating may occur.(See Fig.1)

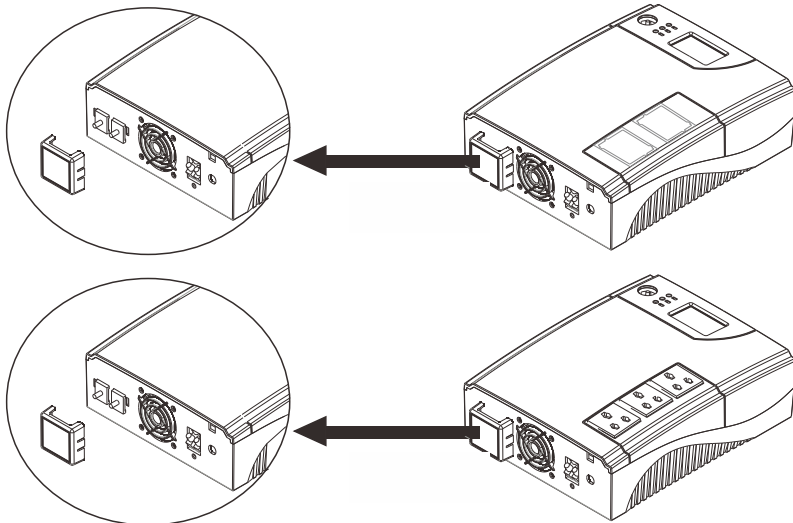

Fig.1

Step4: Install a DC Breaker in a positive line. The rating of the DC Breaker must be according to the inverter's battery current (75Amp). Keep the DC Breaker off.(See Fig.2)

Step5: Connect battery cable to the external batteries.

Note: For the user operation safety, we strongly recommend that you should use tapes to isolate the battery terminals before you start to operate the unit.

1) Single battery connection (Refer to Fig.2) : When using a single battery, its voltage must be equal to the Nominal DC Voltage of the unit.(See below Table 1)

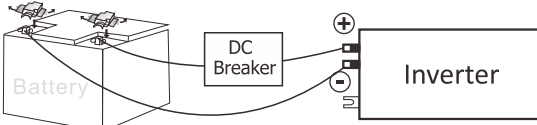

Fig.2

Table 1

Model	Nominal Battery DC Voltage
1200/1800VA	12Vdc
2400VA	24Vdc

2) Multiple batteries in series connection(Refer to Fig.3):The sum of their voltages must be equal to the Nominal DC Voltage of the unit.All batteries must be equal in voltage and amp hour capacity.

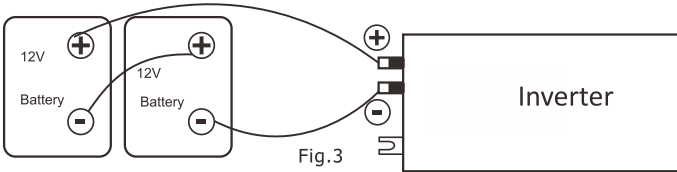

Fig.3

3) Multiple batteries in parallel connection(Refer to Fig.4): Each battery's voltage must be equal to the Nominal DC Voltage of the unit.

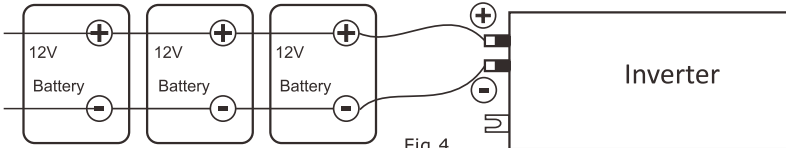

Fig.4

Step 6: Make sure to connect the polarity of battery side and unit correctly.

Positive pole(Red) of battery to the positive terminal(+) of the unit.

Negative pole(Black) of battery to the negative terminal(-) of the unit.

Step 7: Put the covers back to the external battery terminals.

Step 8: Take the DC Breaker on.

Connect to Solar Panel

CAUTION: Before connecting to PV modules, please install separately a DC circuit breaker between inverter and PV modules.

WARNING! All wiring must be performed by a qualified personnel.

WARNING! It's very important for system safety and efficient operation to use appropriate cable for PV module connection. To reduce risk of injury, please use the proper recommended cable size as below.

Typical Amperage	Gauge	Torque Value
50A	8AWG	14-16Nm

Step 1- Connect one cable to the positive(+)pole of solar panel and solar charger positive(+) terminal.

Step 2- Connect the other cable to the negative(-)pole of solar panel and solar charger negative(-) terminal.

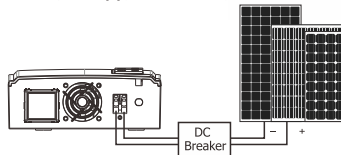

Solar Panel Connection

PV Module Selection

When selecting proper PV modules, please be sure to consider below requirements first:

1. Open Circuit Voltage (Voc) of PV modules does not exceed max. PV array open circuit voltage of inverter

INVERTER MODEL	1200VA/1800VA	2400VA
Charging Current (PWM)	50Amp	
System DC Voltage	12Vdc	24Vdc
Operating Voltage Range	15~18Vdc	30~32Vdc
Max. PV Array Open Circuit Voltage	55Vdc	

2. Max. Power Voltage (Vmp) of PV modules should be close to best Vmp of inverter or within Vmp range to get best performance. If one PV module can not meet this requirement, it's necessary to have several PV modules in series connection. Refer to below table.

Model	Best Vmp	Vmp range
1200VA/1800VA	15Vdc	15~18Vdc
2400VA	30Vdc	30~32Vdc

Note: Vmp: panel max power point voltage.

The PV charging efficiency is maximized while PV system voltage is close to best Vmp.

Maximum PV module numbers in series: Vmp of PV module * X pcs = best Vmp of inverter or Vmp range

PV module numbers in parallel: Max. charging current of inverter / Imp

Total PV module numbers = maximum PV module numbers in series * PV module numbers in parallel

Take 1200/1800VA inverter as an example to select proper PV modules. After considering Voc of PV module not exceed 55Vdc and max. Vmp of PV module close to 15Vdc or within 15Vdc ~ 18Vdc, we can choose PV module with below specification.

Maximum Power (Pmax)	85W	Max. PV module numbers in series
Max. Power Voltage Vmp(V)	17.6V	1 → 17.6 x 1 = 15 ~ 18
Max. Power Current Imp(A)	4.83A	PV module numbers in parallel
Open Circuit Voltage Voc(V)	21.6V	10 → 50 A / 4.83
Short Circuit Current Isc(A)	5.03A	Total PV module numbers
		1 x 10 = 10

Maximum PV module numbers in series: 1

PV module numbers in parallel: 10

Total PV module numbers: 1 x 10 = 10

Take 2400VA inverter as an example to select proper PV module. After considering Voc of PV module not exceed 55Vdc and max. Vmp of PV module close to 30Vdc or within 30Vdc ~ 32Vdc, we can choose PV module with below specification.

Maximum Power (Pmax)	260W	Max. PV module numbers in series
Max. Power Voltage Vmp(V)	30.9V	1 → 30.9 x 1 = 30 ~ 32
Max. Power Current Imp(A)	8.42A	PV module numbers in parallel
Open Circuit Voltage Voc(V)	37.7V	6 → 50 A / 8.42
Short Circuit Current Isc(A)	8.89A	Total PV module numbers
		1 x 6 = 6

Maximum PV module numbers in series: 1

PV module numbers in parallel: 6

Total PV module numbers: 1 x 6 = 6



Operation

Power On/Off







Once the inverter has been properly installed, press the power switch to turn on the unit. The unit will work automatically in line mode or inverter mode according to input utility power's status. When press the power switch again, the unit will be turned off.



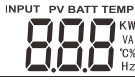



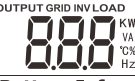







LED Indicators & Audible Alarms

There are three indicators (Green/Red) in the front panel of the unit

LED Indicators		Messages
 Green (Line)	Constant on	Line input voltage normal
	Flashing	Line input voltage fault
 Green (PV)	Constant on	PV input voltage normal
	Off	PV input voltage fault
 Red (Fault)	Constant on	Fault mode
	Flashing	battery low or overload warning
Buzzer Audible Alarms		Messages
Inverter mode (low-battery voltage)		Buzzing every 1 seconds
110% overload warning		Buzzing every 0.5 seconds
Over charge		Buzzing continuously
Fault mode		Buzzing continuously

LCD Display

Display	Function	
Input Source Information		
	Indicates the PV input.	
	Indicate input voltage, input frequency, PV voltage, battery voltage and charger current, version model.	
Configuration Program and Fault Information		
	Indicates the setting programs.	
	Indicates the warning and fault codes. Warning and Fault: flashing with  .	
Output Information		
	Indicate output voltage, output frequency, PV power, load percent, load in Watt version number.	
Battery Information		
	Indicates battery level by 0-25%, 26%-50%, 51-75% and 76-100% in battery mode and charging status in line mode or standby mode.	
In AC mode or standby mode, it will present battery charging status.		
Status	Battery Voltage	LCD Display
Constant Current mode / Constant Voltage mode	< 11Vdc/pcs	4 bars will flash in turns.
	11Vdc ~ 11.5Vdc/pcs	Bottom bar will be on and the other three bars will flash in turns.
	11.5Vdc ~ 12.5Vdc/pcs	Bottom two bars will be on and the other two bars will flash in turns.
	> 12.5Vdc/pcs	Bottom three bars will be on and the top bar will flash.
Floating mode	Batteries are fully charged	4 bars will be on.

In battery mode ,it will present battery capacity.				
Battery Voltage	LCD Display			
< 11Vdc/pcs				
11Vdc ~ 11.5Vdc/pcs				
11. 5Vdc ~ 12.5Vdc/pcs				
> 12.5Vdc/pcs				
Load Information				
  100% 25%	Indicates the load level by 0-25%,26%-50%,51-75% and 76-100%.			
	0-25%	26%-50%	51-75%	76-100%
				
Mode Operation Information				
	Indicates unit connects to the mains.			
	Indicates unit connects to the PV panel.			
BYPASS	Indicates load is supplied by utility power.			
	Indicates the utility charger circuit is working.			
	Indicates the DC/AC inverter circuit is working.			
Mute Operation				
	Indicates unit alarm or button beep is disabled.			

LCD Setting

After pressing and holding "ENTER" button for 2 seconds, the unit will enter setting mode. Press "DOWN" button to select setting programs. And then, press "ENTER" button to confirm the selection or "ESC" button for 2 seconds to exit.

Setting Programs:

Program	Description	Selectable option	
01	Output source priority: To configure load power source priority	Solar first 	Solar energy provides power to the loads as first priority. If solar energy is not sufficient to power all connected loads, battery energy will supply power to the loads at the same time. Utility provides power to the loads only when any one condition happens: - Solar energy is not available. - Battery voltage drops to low-level cut-off voltage or the setting point in program 08.

01	Output source priority: To configure load power source priority	Utility first (default) 01 UT1	Utility will provide power to the loads as first priority. Solar and battery energy will provide power to the loads only when utility power is not available.
		SBU priority 01 SBU	Solar energy provides power to the loads as first priority. If solar energy is not sufficient to power all connected loads, battery energy will supply power to the loads at the same time. Utility provides power to the loads only when battery voltage drops to either low-level cut-off voltage or the setting point in program08
02	Maximum charging current: To configure total charging current for solar and utility chargers (Max. charging current = utility charging current + solar charging current)	10A 02 10A	20A 02 20A
		30A 02 30A	40A 02 40A
		50A (default) 02 50A	60A 02 60A
		70A 02 70A	
03	AC input voltage range	Wide (default) 03 WDE	If selected, acceptable AC input voltage range will be within 90-280VAC.
		Narrow 03 NTU	If selected, acceptable AC input voltage range will be within 170-280VAC.
04	Output frequency	50Hz (default) 04 50 Hz	60Hz 04 60 Hz
05	Maximum utility charging current Note: If setting value in program 02 is smaller than that in program 05, the inverter will apply charging current from program 02 for utility charger.	10A 05 10A	20A (default) 05 20A
06	Charger source priority: To configure charger source priority	If this inverter/charger is working in Line, Standby or Battery mode, charger source can be programmed as below:	
		06 CUT	Utility will charge battery as first priority. Solar energy will charge battery only when utility power is not available.
		Solar first 06 C50	Solar energy will charge battery as first priority. Utility will charge battery only when solar energy is not available.
		Only solar 06 050	Solar energy will be the only charger source no matter utility is available or not.

		Utility +Solar (default) 06 SUN	Max. charging current = utility charging current + solar charging current
		If this inverter/charger is working in Battery mode , only solar energy can charge battery. Solar energy will charge battery if it's available and sufficient.	
07	Low DC cut-off voltage	1200/1800VA model: default setting 10.0V 07 10.0 ^v	
		2400VA model: default setting 20.0V 07 20.0 ^v	
		Setting range is from 10.0V to 12.0V for 1200/1800VA model, 20.0V to 24.0V For 2400VA model. Increment of each click is 0. 1V Low DC cut-off voltage will be fixed to setting value no matter what percentage of load is connected.	
08	Setting voltage point back to utility source when selecting “SBU priority” or “Solar first” in program 01	Available options in 1200/1800VA model:	
		11.5V (default) 08 11.5 ^v	11.0~12.5V (default value is 11.5V)
		Available options in 2400VA model:	
		23.0V (default) 08 23.0 ^v	22.0~25.0V (default value is 23.0V)
09	Setting voltage point back to battery mode when selecting “SBU priority” or “Solar first” in program 01	Available options in 1200/1800VA model:	
		13.5V(default) 09 13.5 ^v	12.0~14.0V (default value is 13.5V)
		Available options in 2400VA model:	
		27.0V(default) 09 27.0 ^v	24.0~28.0V (default value is 27.0V)
11	Auto restart when overload occurs	Restart disable (default) 11 Lfd	Restart enable 11 LfE
13	Backlight control	Backlight on 13 LON	Backlight off (default) 13 LOF
14	Alarm control	Alarm on (default) 14 bON	Alarm off 14 bOF

Display Setting

The LCD display information will be switched in turns by pressing "UP or DOWN" key. The selectable information is switched as below order: input voltage, output voltage, input frequency, output frequency, PV voltage, PV power, charging current, PV power, battery voltage, output voltage, load percentage, load in Watt, CPU version.

Selectable information	LCD display
Input voltage/Output voltage (Default Display Screen)	<p>Input voltage=230V Output voltage=230V</p> <p>INPUT OUTPUT</p> <p>230 V 230 V</p>
Input frequency/Output frequency	<p>Input frequency=50Hz Output frequency=50Hz</p> <p>INPUT OUTPUT</p> <p>500 Hz 500 Hz</p>
PV voltage and power	<p>PV voltage=30V PV power=600W</p> <p>PV</p> <p>30 V 600 W</p>
PV charging current and power	<p>PV Charging current=50A PV power=600W</p> <p>PV</p> <p>50 A 600 W</p>
Battery voltage/Output voltage	<p>Battery voltage=25.5V Output voltage=230V</p> <p>BATT OUTPUT</p> <p>25.5 V 230 V</p>
Battery voltage/Load percentage	<p>Battery voltage=25.5V Load percentage=70%</p> <p>BATT LOAD</p> <p>25.5 V 070 %</p>
Battery voltage/Load in Watt	<p>When load is lower than 1kW, load in W will present xxxW like below chart.</p> <p>BATT LOAD</p> <p>25.5 V 270 W</p>



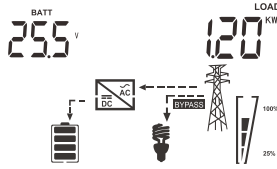



When load is larger than 1kW ($\geq 1\text{KW}$), load in W will present x.xxkW like below chart.



Operating Mode Description

Operation mode	Description	LCD display
Standby Mode Note: Standby mode: The inverter is not turned on yet but at this time, the inverter can charge battery with AC input and PV energy.	Utility input bypass to output, charger available.	Charging by utility.
		Charging by PV energy.
Line Mode	The unit will provide output power from the mains. It will also charge the battery at line mode.	Charging by PV energy.
		Charging by utility.
Battery Mode	The unit will provide output power from battery and /or PV energy.	Power from battery and PV energy.
		Power from battery only.

Fault Reference Code

Fault Code	Fault Event	Icon On
00	Output short circuit	
01	Over load	
03	Output voltage too high	
04	Output voltage too low	
06	Battery voltage too high	
07	Fan fault	
15	Battery voltage low	

Trouble Shooting

Use the table below to solve minor problems

Problem	LCD/LED/Buzzer	Explanation / Possible cause	What to do
When power fails, the battery time is shorter.	Battery low alarm issue quickly.	Battery voltage is too Low.	Charge the unit at least 8 hours.
		Battery capacity is not full even after charge the unit for at least 8 hours.	Check the date code of the battery. If the batteries are too old, replace the batteries.
Mains exists but the unit works in battery mode.	Input voltage is displayed as 0 on the LCD and green LED is flashing.	Input protector is tripped.	Check if AC breaker is tripped and AC wiring is connected well.
	Green LED is flashing.	Insufficient quality of AC power. (Shore or Generator)	1. Check if AC wires are too thin and/or too long. 2. Check if generator (if applied) is working well or if input voltage range setting is correct. (UPS Appliance)
	Green LED is on.	Set "Solar first" or "SBU priority" as the priority of output source.	Change output source priority to Utility first.
	No LED display	Battery is not connected well.	Check the external battery cable and terminal. Make sure all the battery connections to the unit are all correct.
		Battery defect.	Replace the batteries.
Buzzer beeps continuously and red LED is on.	Fault code 00	Output short circuited.	Check if wiring is connected well and remove abnormal load.
	Fault code 01	Overload error. The inverter is overload.	Reduce the connected load by switching off some equipment.
	Fault code 15	Battery voltage too low.	1. Re-charge battery. 2. Replace battery.
	Fault code 03	Output voltage too high.	Return to repair center.
	Fault code 04	Output voltage too low.	Return to repair center.
	Fault code 06	Battery voltage too high.	Check the battery specifications.
	Fault code 07	Fan fault.	Replace the fan.

Specifications

MODEL	1200VA	1800VA	2400VA
CAPACITY	720W	1000W	1440W
INPUT			
Voltage	230 VAC		
Voltage Range	170~280 VAC(Narrow Range) 90~280 VAC (Wide Range)		
OUTPUT			
Voltage Regulation (Batt. Mode)	+ 10/-18%		
Transfer Time	20 ms typical		
Waveform	Modified sine wave		
BATTERY			
Battery Voltage	12 VDC	24 VDC	
Boost Voltage	14.4VDC±0.2VDC	28.8VDC±0.3VDC	
Floating Charge Voltage	13.7VDC±0.2VDC	27.4VDC±0.3VDC	
Maximum Charge Current	10A or 20A		
SOLAR CHARGER			
Maximum Charging Current	50 A		
System Voltage	12 VDC	24 VDC	
Operating Voltage Range	15 ~ 18 VDC	30 ~ 32 VDC	
Max. PV Array Open Circuit Voltage	55VDC		
PHYSICAL			
Dimension (D*W*H) mm (Plastic)	295 x230 x85		
Net Weight (kgs)(Plastic)	2.6	2.8	
Dimension (D*W*H) mm(Iron Piecesc)	290 x 252 x 99		
Net Weight (kgs)(Iron Piecesc)	4.0	4.2	

**MUST**[®]

GUARANTEE CERTIFICATE

Serial No.: _____

Customer's Name				Contact Person	
Address				Telephone No.	
Product/Model:		Post Code		Fax No.	
Date of purchase			Expire Date		
Dealer Signature			Customer Signature		

**MUST**[®]

GUARANTEE CERTIFICATE

Serial No.: _____

Customer's Name				Contact Person	
Address				Telephone No.	
Product/Model:		Post Code		Fax No.	
Date of purchase			Expire Date		
Dealer Signature			Customer Signature		