



USER'S MANUAL

Solar Charger Controller

30A/40A

Please download the software "SolarPowerMonitor2.2.81".
Download link: <https://bit.ly/2PyyLg6>



Appliances



PC



TV



Air-conditioning



Fridge



Washing machine

CONTENTS

1.ABOUT THIS MANUAL.....	1
1.1 Purpose.....	1
1.2 Scope.....	1
1.3 Safety Instructions.....	1
2.INTRODUCTION.....	2
2.1 Features.....	2
2.2 Product Overview.....	2
3.INSTALLATION.....	3
3.1 Unpacking and Inspection.....	3
3.2 Preparation.....	3
3.3 Mounting the Unit.....	3
3.4 Power Connection.....	4
3.5 Battery Temperature Sensor.....	5
3.6 Communication Connections.....	6
4.OPERATION.....	6
4.1 Power-Up.....	6
4.2 Operation and Display Panel.....	7
4.3 LCD Display Icons.....	8
4.4 LCD Setting.....	9
4.5 Reference Code.....	13
5.CHARGING LOGIC.....	14
5.1 3-stage Charging.....	14
5.2 Equalize Stage.....	15
5.3 Setting Parameter and Default Value.....	19
6.PARALLEL CHARGING FUNCTION.....	19
7.SPECIFICATIONS.....	20

1.ABOUT THIS MANUAL

1.1 Purpose

This manual describes the assembly, installation and operation of this unit. Please read this manual carefully before installations and operations.

1.2 Scope

This manual provides safety and installation guidelines as well as information on tools and wiring.

The following cases are not within the scope of warranty:

- (1) Out of warranty.
- (2) Series number was changed or lost.
- (3) Battery capacity was declined or external damaged.
- (4) Solar charger controller was damaged caused of transport shift, remissness, ect external factor.
- (5) Solar charger controller was damaged caused of irresistible natural disasters.
- (6) Not in accordance with the electrical power supply conditions or operate environment caused damage.

1.3 Safety Instructions

 **WARNING:** This chapter contains important safety and operating instructions. Read and keep this manual for future reference.

1. Before using the unit, read all instructions and cautionary markings on the unit, the batteries and all appropriate sections of this manual.
2. Do not disassemble the unit. Take it to a qualified service center when service or repair is required. Incorrect re-assembly may result in a risk of electric shock or fire.
3. To reduce risk of electric shock, disconnect all wirings before attempting any maintenance or cleaning. Turning off the unit will not reduce this risk.
4. **CAUTION**- Only qualified personnel can install this device with battery.
5. **NEVER** charge a frozen battery.
6. For optimum operation of this charger, please follow required spec to select appropriate cable size. It's very important to correctly operate this charger.
7. Be very cautious when working with metal tools on or around batteries. A potential risk exists to drop a tool to spark or short circuit batteries or other electrical parts and could cause an explosion.
8. Please strictly follow installation procedure when you want to disconnect PV or battery terminals. Please refer to INSTALLATION section of this manual for the details.
9. **GROUNDING INSTRUCTIONS**- This charger should be connected to a permanent grounded wiring system. Be sure to comply with local requirements and regulation to install this charger.
10. **NEVER** cause short circuited on battery output.
11. **Warning!!** Only qualified service persons are able to service this device. If errors still persist after following troubleshooting table, please send this charger back to local dealer or service center for maintenance.

2. INTRODUCTION

Thank you for selecting this solar charge controller. This solar charge controller is an advanced solar charger with maximum power point tracking. Applying intelligent MPPT algorithm, it allows solar charge controller to extract maximum power from solar arrays by finding the maximum power point of the array.

The MPPT battery charging process has been optimized for long battery life and improved system performance. Self-diagnostics and electronic error protections prevent damage when installation errors or system faults occur. This charger also features multifunctional LCD with communication ports for remote battery temperature and voltage measurement.

2.1 Features

- Intelligent Maximum Power Point Tracking technology increases efficiency 25%~30%
- Compatible for PV systems in 12V,or24V
- Three-stage charging optimizes battery performance
- Maximum charging current up to 20A/30A/40A
- Advanced MPPT technology,with efficiency no less than 99%
- Maximum DC – DC conversion efficiency of 98%
- Battery temperature sensor(BTS) automatically provides temperature compensation
Automatic battery voltage detection
- Support wide range of lead-acid batteries including flooded, AGM, GEL,LEAD,Lithium Ion, User-Defined batteries.
- Integrated intelligent slot compatible with 485 communication

2.2 Product Overview

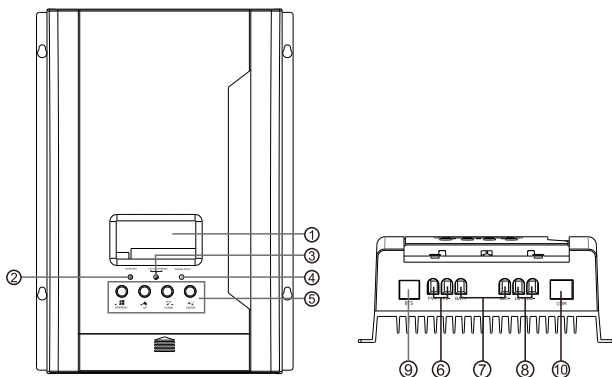

1. LCD display
2. Charging indicator
3. Fault and warning indicator
4. Wiring fault indicator
5. Operation button
6. PV connectors
7. Battery connectors
8. Load connectors
9. Battery temperature sensor terminal
10. RS485 communication port

3. INSTALLATION

3.1 Unpacking and Inspection

Before installation, please inspect the unit. Be sure that nothing inside the package is damaged. You should have received the following items inside of package:

- Solar charge controller×1
- User manual×1
- Communication cable×1
- Battery Temperature Sense×1

3.2Preparation

Before connecting all wirings, please take off wiring box cover by removing screws as shown below.

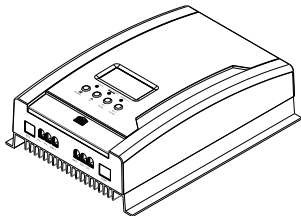

3.3 Mounting the Unit

Consider the following points before selecting where to install:

- This solar charge controller is designed in Ip30.
- Do not mount the unit on flammable construction materials.
- Mount on solid surface
- Install this charger at eye level in order to allow the LCD display to be read at all times.
- For proper air circulation to dissipate heat, allow a clearance of approx. 300 mm to the side and approx. 300 mm above and below the unit.
- The ambient temperature should be between -10°C and 50°C to ensure optimal operation.
- The recommended installation position is to be adhered to The wall vertically.

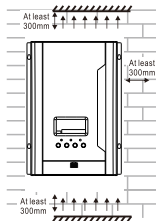

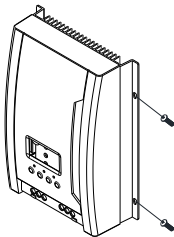

Install the unit to the wall by screwing four screws.
Refer to right chart.

3.4 Power connection

Wire size

The wiring and installation methods must conform to all national and local electrical code requirements.

PV Wire Size

Since PV array output can vary due to the PV module size, connection method or sunlight angle, the minimum wire size can be calculated by the I_{sc} of PV array. Please refer to the value of I_{sc} in the PV module specification. When PV modules connect in series, the I_{sc} is equal to a PV modules I_{sc} . When PV modules connect in parallel, the I_{sc} is equal to the sum of the PV module's I_{sc} . The I_{sc} of the PV array must not exceed the controller's maximum PV input current. Please refer to the table as below:

NOTE: All PV modules in a given array are assumed to be identical.

I_{sc} =short circuit current(amps) V_{oc} =open circuit voltage.

Max. PV input current	Max. PV wire size
30A	10mm ² /8AWG
40A	16mm ² /6AWG

These are the maximum wire sizes that will fit the controller terminals.

Battery and Load Wire Size

The battery and load wire size must conform to the rated current, the reference size as below:

Rated charge current	Rated discharge current	Battery wire size	Load wire size
30A		10mm ² /8AWG	
40A		16mm ² /6AWG	

NOTE: The wire size is only for reference. If there is a long distance between the PV array and the controller or between the controller and the battery, larger wires can be used to reduce the voltage drop and improve performance.

Overcurrent Protection and Disconnects

CAUTION: Circuit breakers or fuses must be installed in both battery and solar circuits.

The battery circuit breaker or fuse must be rated to 125% of the maximum current or more.

The recommended breaker/fuse rating for use with the charger is listed in the below table.
recommended breaker rating:

The battery circuit breaker or fuse must be rated to 125% of the maximum current or more. The recommended breaker/fuse rating for use with the charger is listed in the below table.

recommended breaker rating:

Minimum battery circuit breaker / fuse rating	
3015A	4015A
$1,25 \times 30 \text{Amps} = 37,5 \text{Amps}$	$1,25 \times 40 \text{Amps} = 50 \text{Amps}$

A disconnect is required for the battery and solar circuits to provide means for removing power from the charger. Double pole switches or breakers are convenient for disconnecting both solar and battery conductors simultaneously.

Connect the Power Wires

WARNING: Shock Hazard

The solar modules can produce open-circuit voltage in excess of 150V(12Vdc,24Vdc) when in sunlight. Verify if solar input breaker or disconnect has been opened(disconnected) before connecting system wires.

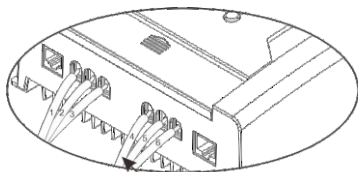

PV+, PV-, BA+, BA-, LO+, LO-
(common negative)

Connect terminals by following below steps(Refer to diagram above):

1. Make sure that the system input and output disconnect switches are both turned off before connecting power wires to the charger. There are no disconnecting switches inside the charger.
2. Make 4 power wires first. Remove insulation sleeve 10.5mm and the conductor should be plated Tin. Refer to the chart below.

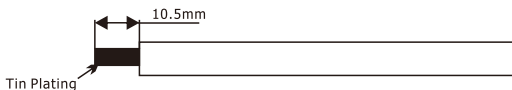

3. Pull all wires into the wiring box. The Battery Temperature Sensor can be inside the conduit with the power conductors. It is easier to pull BTS before the power cables.

WARNING:Risk of Damage

Be sure that the battery connection is made with correct polarity. Turn on the battery breaker/disconnect and measure the voltage on the open battery wires BEFORE connecting to the controller. Disconnect the battery breaker/disconnect before wiring to the controller.

1. Connect positive terminal(+) of battery to the battery positive terminal(+) on the controller.
2. Connect negative terminal(-) of battery to one of the common negative terminals(-)on the controller.

WARNING:Risk of Damage

Be sure that solar connection is made with correct polarity. Turn on the solar breaker/disconnect and measure the voltage on the open battery wires BEFORE connecting to the controller. Disconnect solar breaker/disconnect before wiring to the controller.

6. Connect positive wire(+) of solar module to the solar positive terminal(+) on the controller.
7. Connect negative wire(-) of solar module to one of the common negative terminals(-)on the controller.
8. Screw four(4) power terminals tightly with 50 in-lbs torque.(5.65Nm)

3.5 Grounding and Ground Fault Interruption

Use a copper wire to connect the grounding terminal in the wiring box to earth ground. The grounding terminal is identified by the ground symbol shown below that is stamped into the wiring box just below the terminal: 

3.6 Battery Temperature Sensor

The included Battery Temperature Sensor(BTS) is recommended for effective temperature compensated charging. Connect the BTS to the 2-pole terminal(see figure as below). The BTS is supplied with RJ11,33ft(1m) of 22AWG(0.34mm²) cable.

NOTE: The BTS is optional package. Please check local dealer for the details.

CAUTION: The controller will not activate temperature compensate charging function if the BTS is not used.

CAUTION:Equipment Damage

Never place the temperature sensor inside a battery cell. Both the BTS and the battery will be damaged.

NOTE: The BTS cable may be shortened if the full length is not needed.

3.7 Communication Connections

The default Communication of the controller is RS485 port. You can use supplied cable to connect RS-485, port of controller to PC. It can be used for monitoring or upgrade the firmware in short distance.

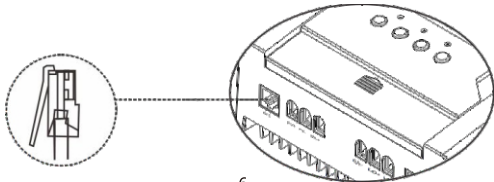

WARNING : It's forbidden to use network cable as the communication cable to directly communicate with the PC port. Otherwise, the internal components of the controller will be damaged.

WARNING : RJ45 interface is only suitable for the use of the company's supporting products or professional operation.

Below chart is showed RJ45 Pins define

Pin	Define
1	RS-485-B
2	RS-485-A
3	GND
4	
5	
6	
7	
8	

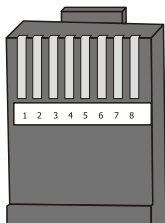

4. OPERATION

4.1 Power-up

WARNING: Risk of Damage

Connecting the solar module to the battery connector will permanently damage the controller.

- Confirm that the solar and battery polarities are correctly connected to the controller.
- A battery must be connected to the controller before operating it. The controller will not operate only with solar input. Solar input can trigger the controller to start up when the battery is connected without pressing the button.
- Turn on battery disconnect switch first. And press operation button for a while. Then , it will indicate a successful start-up in LCD display.
- Turn on solar disconnect switch. If the solar module is in full sunlight, the controller will begin charging.

4.2 Operation and Display Panel

The operation and display panel, shown in below chart, is on the front panel of the controller. It includes three indicators, one operation button and a LCD display, indicating the operating status and input/output power information.

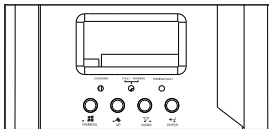

LED Indicator

LED Indicator		Messages	
POWER ON/ CHARGING	Green	Solid On	The controller is on.
		Flashing	The controller is charging. Bulk charge stage : flashing every 0.5 second Absorption stage : flashing every second Equalize stage : flashing every 3 seconds Float stage : flashing every 5 seconds
FAULT/WARNING	Red	Solid On	Fault occurs.
		Flashing	Warning situation occurs.
WIRING FAULT	Red	Solid On	Battery polarities are not connected correctly.



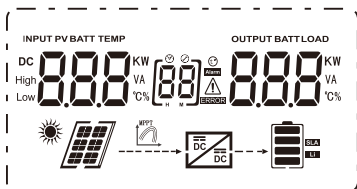

Function Keys

Function Keys	Description.
MENU	Enter reset mode or setting mode go to previous selection.
UP	Increase the setting data.
DOWN	Decrease the setting data.
ENTER	Enter setting mode and Confirm the selection in setting mode go to next selection or exit the reset mode.

4.3 LCD Display Icons



Icon	Function description
Input Source Information	
INPUT PV BATT TEMP DC 888 KW High VA Low °C%	Indicates the PV input voltage, battery voltage.
Configuration Program and Fault Information	
E9	Indicates battery equalization is activated.
[88]	Indicates the setting programs.
[88] ⚠	Indicates the warning and fault codes.
Output Information	
	Indicates battery level by 0-24%, 25-49%, 50-74%, and 75-100% in battery mode and charging status in line mode.
	Indicates MPPT solar charge controller work pattern.

  	Load ON	
 	Load OFF	
BATT LOAD 28.0 °C 35.9 A	Battery Temperature, Load Current	
BATT OUTPUT DC 12.2 V 37.0 A	Battery Voltage, output charging current	
PV OUTPUT DC 61.2 V 45.0 W	PV Voltage, Indicate output power.	
Battery Charging Status		
status	Battery Voltage	LCD Display
Constant Current mode/ Constant Voltage mode	<2V/cell	4 bar will flash in turns.
	2V/cell~2.083V/cell	The right bar will be on and the other bars will flash in turns.
	2.083V/cell~2.167V/cell	The two right bars will be on and the other two bars will flash in turns
	>2.167V/cell	The three right bars will be on and the left bar will flash.
Floating mode	Batteries are fully charged.	4 bars will be on.

4.4 LCD setting

After pressing and holding "ENTER" button for 3 seconds, the unit will enter setting mode. Press "UP" or "DOWN" button to select setting programs. And then, press "ENTER" or "MENU" button to confirm the selection and exit.

Setting Programs:

Program	Description	Options	
00	Exit setting mode	Escape [00] ESC	
01	Maximum charging current	[01] 300 A	Setting range is form 10.0A to 30.0A. Increment of each click is 1A.
		[01] 400 A	Setting range is form 10.0A to 40.0A. Increment of each click is 1A.
02	Battery type	AGM(Default) [02] AGM	Flooded [02] FLd
		GEL [02] GEL	LEAD [02] LEA
		Lithium Ion [02] LI	User-Defined [02] USE
		If "User-Defined" LI is selected, battery charge voltage can be set up in program 03 and 04.	
03	Absorption voltage	[03] 14.4	The setting range is from 12.0V to 16.0V.
		[03] 28.8	The setting range is from 24.0V to 32.0V.
04	Float voltage	[04] 13.7	The setting range is from 12.0V to 16.0V.
		[04] 27.4	The setting range is from 24.0V to 32.0V.
05	Battery rated voltage	Auto(Default) [05] AUO	If "AUO" is selected, connected battery voltage system will be automatically detected.
		[05] 12	If "12V" is selected, the unit is considered as 12V battery system.
		[05] 24	If "24V" is selected, the unit is considered as 24V battery system.
06	Battery C.V. Charging duration	(Default) [06] 150	The setting range is form 5 minutes to 900 minutes. Increment of each short press is 5 minutes. It will jump back to 5 minutes after 900 is achieved.

07	BTS temperature compensation ratio	0mV(Default) [0]00	The setting range is from 0mV to 60.0mV. Increment of each short press is 0.1mV. The value will jump back to 0mV after 60.0mV is achieved. For each 12 Battery, the derated battery charging voltage is followed the below formula: (Battery temperature-25°C) *BTS ratio
08	Battery equalization enable/disable	Disable(Default) [08]E9d	Enable [08]E9E
09	Battery equalization voltage	[09]146	The setting range is from 12.0V to 16.0V.
		[09]292	The setting range is from 24.0V to 32.0V.
10	The maximum current of battery equalization	15A(Default) [10]150	The setting range is from 5A to 40A. Increment of each short press is 1A. The value will jump back to 5A after 40A is achieved.
11	Battery equalization time	60minutes(Default) [11]60	The setting range is form 5 minutes to 900 minutes. Increment of each short press is 5 minutes. The value will jump back to 5 minutes after 900 minutes is achieved.
12	Battery equalization overtime	120minutes(Default) [12]120	The setting range is form 5 minutes to 900 minutes. Increment of each short press is 5 minutes. The value will jump back to 5 minutes after 900 minutes is achieved.
13	Equalization interval	30days(Default) [13]30d	The setting range is from 1 day to 90 days.
14	Equalization activated immediately	Disable(Default) [14]Ad5	If "Enable" is selected in this program, it's to activate battery equalization immediately and LCD main page will shows "E9". If "Disable" is selected, it will cancel equalization function until next activated equalization time arrives based on

		Enable [14]REN	program 13 setting. At this time, "E9" will be shown in LCD main page too.
15	Auto turn page	(default) [15]PTE	If selected, the display screen will auto turn the display page.
		[15]Ptd	If selected, the display screen will stay at latest screen user finally switches.
16	Backlight control	Backlight on [16]LON	Backlight off(Default) [16]LOF
17	Low DC cut-off load voltage setting	11.1V (default) [17] 11.1 _v	The setting range is from 9.0V to 16.0V.
		22.2V (default) [17] 22.2 _v	The setting range is from 18.0V to 32.0V.
18	Low DC return load voltage setting	12.6V (default) [18] 12.6 _v	The setting range is from 9.0V to 16.0V.
		25.2V (default) [18] 25.2 _v	The setting range is from 18.0V to 32.0V.
19	Timer1 (Load working mode)	100 (default) [19] 100	Light ON/OFF
		101→115 [19] 101	Load will be on for 1→15 hours since sunset
		116 [19] 116	Load will be on since sunset, and Load will be off since sunrise
		117 [19] 117	Load will be on at all hours.
		118 [19] 118	Load will be off at all hours.

20	Auto turn page	2n(default) 	Default, Cannot setting
		201→218 	Load will be on for 1→18 hours before sunset

After pressing and holding "MENU" button for 6 seconds, the unit will enter reset model. Press "UP" and "DOWN" button to select programs. And then, press "ENTER" button to exit.

	(default) 	Reset setting disable
		Reset setting enable

4.5 Reference Code

Fault Code	Fault Cause	LCD Indication
01	Battery voltage class error	
02	Hardware protection	
03	Output Over current	
04	Battery voltage is too low	
05	Battery voltage is too high	
06	Current is uncontrollable	
07	Over temperature	
08	Current sensor error	
09	PV voltage is too high	
11	Voltage point setting error	
12	Load Over current	

5.CHARGING LOGIC

5.1 3-stage Charging

In general, this solar charge controller is designed with 3-stage battery charging algorithm for fast, efficient, and safe battery charging. The following picture shows the sequence of charging stages.

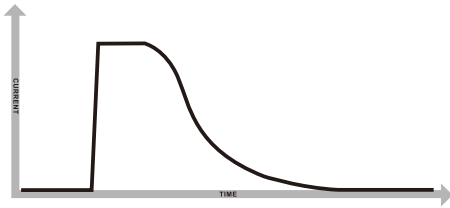
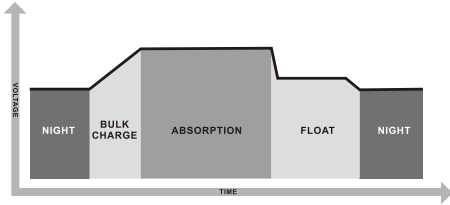

1) Bulk charge stage

In bulk charge stage, charge current begins to flow, typically at the maximum rate of The controller will supply solar power to charge battery as much as possible.

2) Absorption stage

When battery charging voltage is reached to Absorption voltage point, the charging stage changes from bulk charge to Absorption. Constant-voltage regulation is used to maintain battery voltage at the Absorption stage. No matter what the maximum charge current value is set, when the charging current drops to 10A, the charging status will change to Float stage.

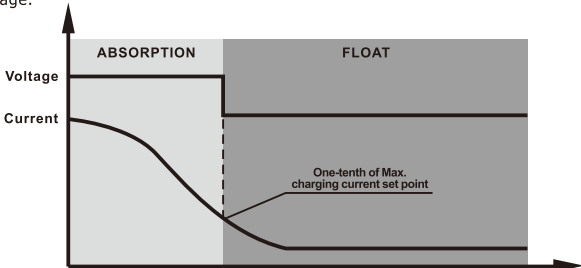

If the elapsed time of absorption stage is over setting value for C-V charging time, it will also transfer to Float stage.

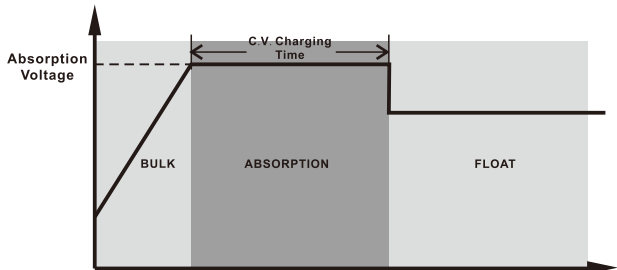

3) Float stage

After the battery is fully charged in the Absorption stage, the controller will reduce the battery voltage to the setting point of Float voltage. Once in Float stage, constant-voltage regulation is used to maintain battery voltage at setting point of float voltage.

• **Float timeout**

If the battery voltage remains lower than the Float voltage for 30 minutes, the controller will return to Bulk charging stage.

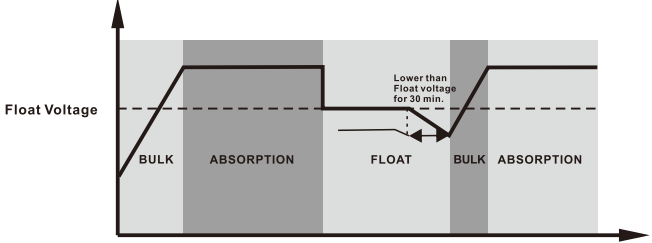

• **Float cancel voltage**

Once the battery voltage drops to setting point of Float cancel voltage, the controller also returns to Bulk charging stage.

Float cancel voltage = Floating charging voltage -- (1V × battery numbers in series)

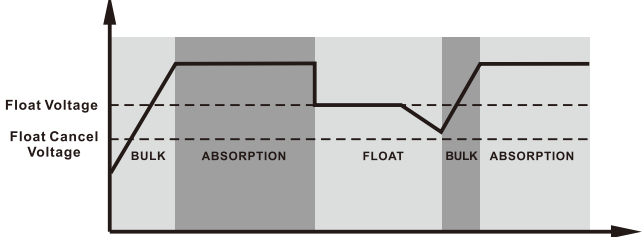

5.2 Equalize Stage

Equalization function is added into solar charge controller. It reverses the buildup of negative chemical effects like stratification, a condition where acid concentration is greater at the bottom of the battery than at the top. Equalization also helps to remove sulfate crystals that might have built up on the plates. If left unchecked, this condition, called sulfation, will reduce the overall capacity of the battery. Therefore, it's recommended to equalize battery periodically.

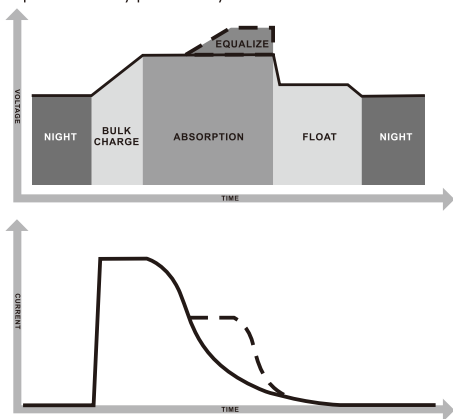

• How to Apply Equalization function

You must enable battery equalization function in monitoring software first.

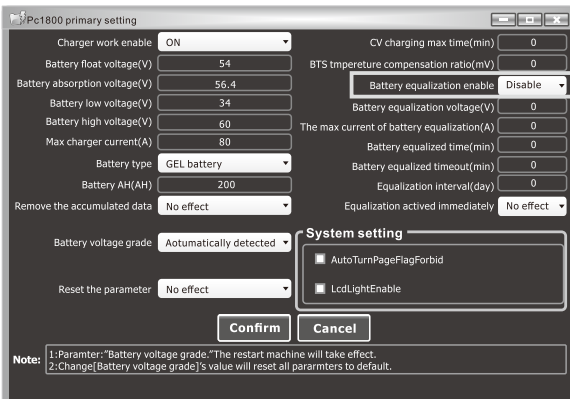

Then, you may apply this function in device by either one of following methods:

1. Setting equalization interval.
2. press the "confirm" button for 3 seconds until LCD shows "EQ"

- **When to Equalize**

In Absorption stage, if the charging current drops lower than the maximum charging current of battery equalization, the controller will start to enter Equalize stage.

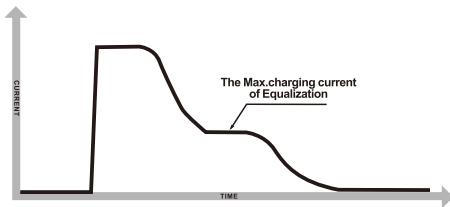
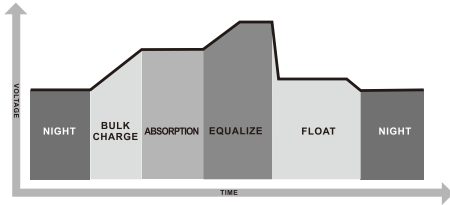

If solar charge controller is working in float stage, but at this time, the setting equalization interval (battery equalization cycle) is arrived, it will transfer to equalize stage.

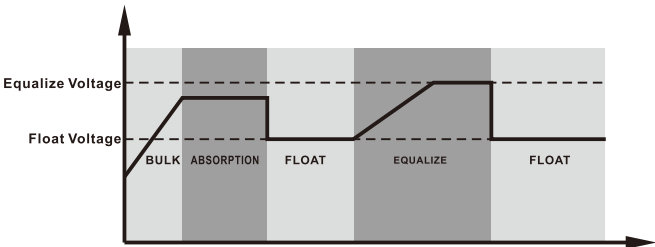

- **Equalize charging time and timeout**

In Equalize stage, based on maximum charging current of battery equalization, the controller will supply solar power to charge battery as much as possible until battery voltage raises to battery equalization voltage. Then, constant-voltage regulation is applied to maintain battery voltage at the battery equalization voltage. The battery will remain in the Equalize stage until setting battery equalized time is arrived.

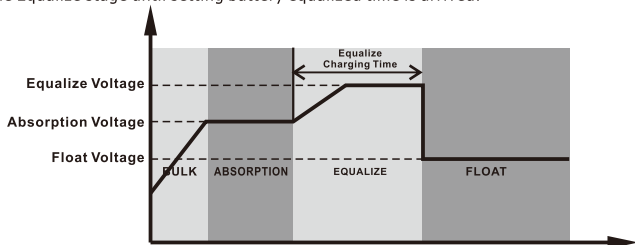

However, in Equalize stage, when battery equalized time is expired and battery voltage doesn't rise to battery equalization voltage point, the solar charge controller will extend the battery equalized time until battery voltage achieves battery equalization voltage. If battery voltage is still lower than battery equalization voltage when battery equalized time setting is over, the solar charge control will stop equalization and transfer to float stage.

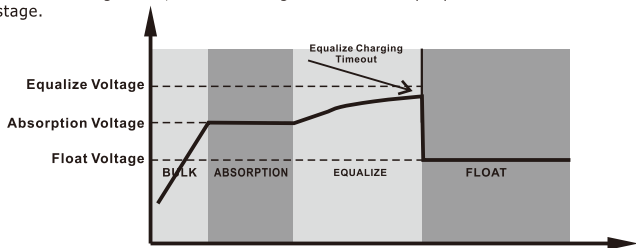

5.3 Setting parameter and Default Value

Recommended and default parameter setting are listed below.

Parameter	Battery type	Absorp. Stage	Float Stage	Equalize Stage	Equalize Activation	Absorp. Time	Equalize Time	Equalize Timeout	Equalize Interval
Unit	—	volt	volt	volt	En/Disable	Minutes	Minutes	Minutes	Days
Default	AGM/Gel/LEAD	14.4V	13.7V	14.6V	Disable	150	60	120	30
Option	Flooded	14.2V	13.7V	14.6V	Disable	150	60	120	30
Option	Customized	14.1V	13.5V	14.6V	Disable	150	60	120	30

6. PARALLEL CHARGING FUNCTION

Users can assign chargers in different groups, the same group will be parallel charged to the same batteries.

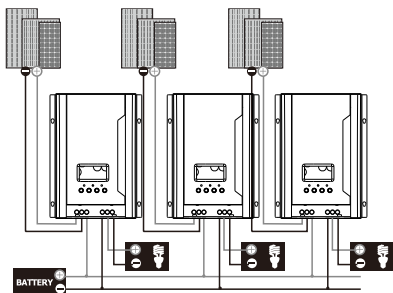

7. SPECIFICATIONS

Table 1 Electrical Specifications

MODEL	30A	40A																		
Nominal System Voltage	12V,24V (Auto detection)																			
Maximum Battery Current	30Amps	40Amps																		
Battery Voltage	12V	24V																		
Maximum Solar Input Voltage	150V																			
PV Array MPPT Voltage Range	≤ 145V																			
Maximum Input Power	12 Volt-432W 24 Volt-864W	12 Volt-576W 24 Volt-1152W																		
Heatsink temperature & Battery current	<table border="1"> <caption>Graph Data: Rated current percent (%) vs Heatsink Temperature (degrees C)</caption> <thead> <tr> <th>Heatsink Temperature (degrees C)</th> <th>Rated current percent (%)</th> </tr> </thead> <tbody> <tr> <td>60</td> <td>40</td> </tr> <tr> <td>65</td> <td>40</td> </tr> <tr> <td>70</td> <td>40</td> </tr> <tr> <td>75</td> <td>40</td> </tr> <tr> <td>80</td> <td>30</td> </tr> <tr> <td>85</td> <td>20</td> </tr> <tr> <td>90</td> <td>10</td> </tr> <tr> <td>95</td> <td>0</td> </tr> </tbody> </table>		Heatsink Temperature (degrees C)	Rated current percent (%)	60	40	65	40	70	40	75	40	80	30	85	20	90	10	95	0
Heatsink Temperature (degrees C)	Rated current percent (%)																			
60	40																			
65	40																			
70	40																			
75	40																			
80	30																			
85	20																			
90	10																			
95	0																			
Protections	Solar high voltage disconnect Solar high voltage reconnect Battery high voltage disconnect Battery high voltage reconnect High temperature disconnect High temperature reconnect																			

Table 2 Battery Charging

MODEL	30A/40A	
Charging Algorithm	3-Step or 4-Step(LI)	
Charging stages	Bulk, Absorption, Float	
Temperature compensation coefficient	-5mV/°C /cell(25°C ref.)	
Temperature compensation range	0°C to +50°C	
Temperature compensated set points	Absorption, Float	
Charging Set points	Absorption Stage	Float Stage
Flooded Battery	14.2V/28.4V	13.7V/27.4V
AGM/Gel/LEAD battery (Default)	14.4V/28.8V	13.7V/27.4V
Over-charging voltage	15.5V/30.0V	
Over-charging comeback voltage	14.5V/29.5V	
Battery defect voltage	10.0V/17.0V	
Charging Curve		

Table 3 Mechanical and Environment

Charger MODEL	30A/40A
Product size(W×HxD,MM)	187x255x72
Product weight(Kg)	2.65Kg
Ambient Temperature Range	-10°C to 50°C
Storage Temperature	-10°C to 70°C
Humidity	0%-90% RH(No condensing)
Enclosure	IP30

MUST[®]

GUARANTEE CERTIFICATE

Serial No.: _____

Customer's Name				Contact Person	
Address				Telephone No.	
Product/Model:		Post Code		Fax No.	
Date of purchase			Expire Date		
Dealer Signature			Customer Signature		

**MUST[®]**

GUARANTEE CERTIFICATE

Serial No.: _____

Customer's Name				Contact Person	
Address				Telephone No.	
Product/Model:		Post Code		Fax No.	
Date of purchase			Expire Date		
Dealer Signature			Customer Signature		