



100% PURE SINE WAVE HOME INVERTER

# USER'S MANUAL

## SOLAR ENERGY STORAGE SYSTEM

1-3KW

Please download the software "SolarPowerMonitor2.2.81".  
Download link: <https://en.must-ee.com>



Scan QR code for manual



Appliances



PC



TV



Air-  
conditioning



Fridge



Washing  
machine

4200-100003-00A1



# Contents

<b>ABOUT THE MANUAL</b> .....	1
Purpose.....	1
Scope.....	1
<b>SAFETY NOTICE</b> .....	1
<b>INTRODUCTION</b> .....	2
Features.....	2
Basic System Structure.....	2
Product Overview.....	3
<b>BEFORE OPERATION</b> .....	4
Unpacking and Inspection.....	4
Preparation.....	4
Input and Output Connection.....	4
PV Panel Connection.....	4
PV Panel Selection.....	5
<b>OPERATION</b> .....	6
Power ON/OFF.....	6
Operation and Display Panel.....	6
LCD Display Icons.....	7
LCD Setting .....	8
Fault Reference Code .....	14
Warning Indicator .....	15
Operating State Description .....	16
Display Setting .....	17
<b>SPECIFICATIONS</b> .....	18
<b>TROUBLE SHOOTING</b> .....	19

## ABOUT THE MANUAL

### Purpose

This manual describes the operation and troubleshooting of the equipment. Please read this manual carefully before operation.

Retain this manual for future reference.

### Scope

This manual provides safety guidelines and information on tools and wiring.

### The following situations are not covered by the warranty :

- (1) Overdue the warranty period .
- (2) The serial number has been changed or lost.
- (3) The battery capacity is the lowest or the appearance of the device is damaged.
- (4) External factors such as transportation, negligence, etc.
- (5) This equipment has been damaged by an irresistible natural disaster .
- (6) Damage caused by not following the power supply conditions or operating environment .

## SAFETY NOTICE



**WARNING:** This chapter contains important safety and operating instructions. Read and save this manual for future reference.

- 1.** Before using this unit , please read all instructions and precautions on this unit , understand all relevant chapters in this manual to Prevent explosion which may lead to personal injury and battery damage.
- 2.** Do not disassemble the unit . When service or repair is required , send it to a professional service center . Incorrect assembly may result in electric shock or fire.
- 3.** To reduce the risk of electric shock , disconnect all wiring before attempting any maintenance or cleaning . Turning off the device does not reduce this risk.
- 4.** Caution - Only professionals should install this device.
- 5.** Grounding Instructions - This equipment should be connected to a permanently grounded wiring system. Be sure to comply with local requirements and regulations to use this device.

## INTRODUCTION

This is a multi-functional photovoltaic energy storage power station, integrated with battery, MPPT solar charge controller, high frequency pure sine wave inverter and UPS function module into one , which is suitable for outdoor backup electric compartment and spontaneous self-use system .

MPPT solar charge controller adopts advanced MPPT method and intelligent battery management design, which ensures the acquisition of maximum energy ;High frequency pure sine wave inverter adopts high frequency design , achievement high rate density , small size , simple operation and other advantages; The whole machine has high efficiency and the empty load loss is small ,which uses large capacity basket and high-density hammer pool to improve portability of the system.

## Features

- Pure sine Wave AC Output Inverter with 1KW - 3KW rated power and power factor 1.
- High power density with universal wheels and high portability.
- Setting input voltage and voltage range on the LCD Screen.
- 5V USB and 12V DC output supported.
- AC/PV input and battery priority level configurable on LCD.
- Protection functions such as overload, over temperature and short circuit.

## Basic System Structure

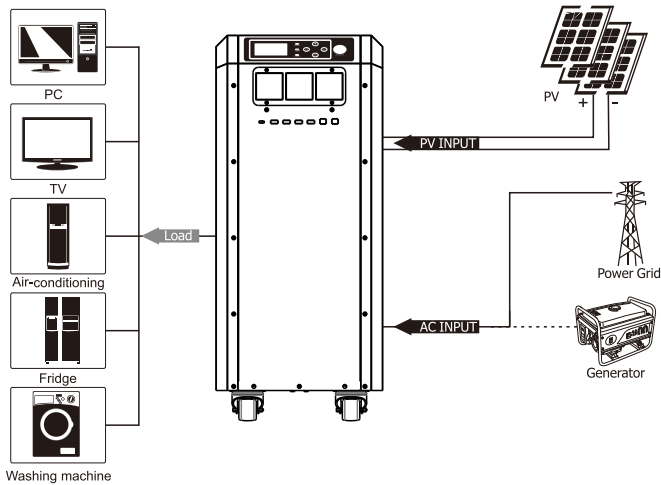

# Product Overview

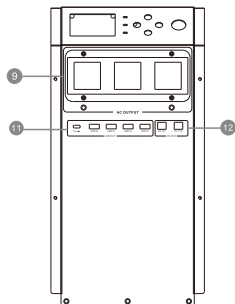
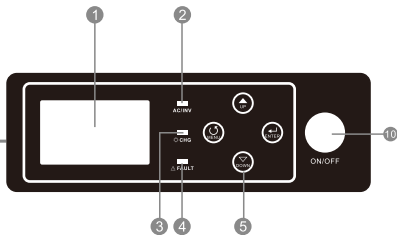
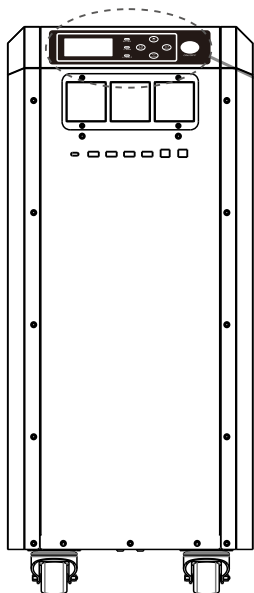

(1K)

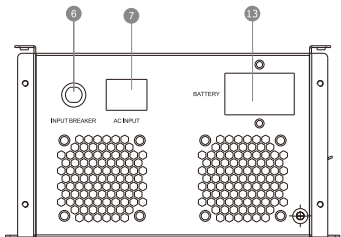

(1K)

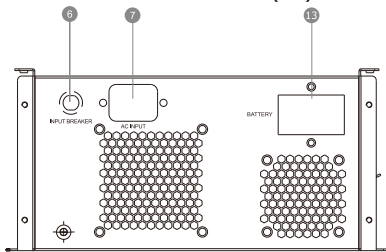
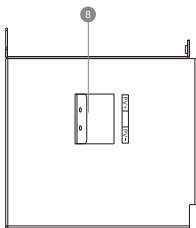

(2~3K)

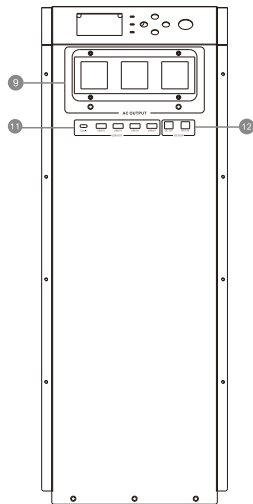
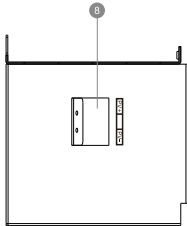

(2~3K)

- 1. LCD display
- 2. Status Indicator
- 3. Charge/discharge Indicator
- 4. Fault Indicator
- 5. Function Button
- 6. AC input over-current protection
- 7. AC input

- 8. PV input
- 9. AC output
- 10. Switch
- 11. DC5V USB output
- 12. DC12V output
- 13. BATTERY breaker

## BEFORE OPERATION

### Unpacking and Inspection

Make sure nothing in the package is damaged. You should have received the following items inside the package.

- Machine X 1
- User manual X 1
- Mains input line X 1

### Preparation

Before turning on the device, please reserve a distance of more than 300mm above the device and 200mm to the left and right to ensure for heat dissipation, To ensure the best operation, the ambient temperature should be between 0-50 ° C.

### Input and Output Connection

- 1.After power on, you can directly take power from the AC output.
- 2.DC output powered without turning on.
- 3.Connect the grid and the AC input terminal with the matching wires to load the mains .
- 4.Please make sure the cable is firmly connected and do not move the machine while it is running .

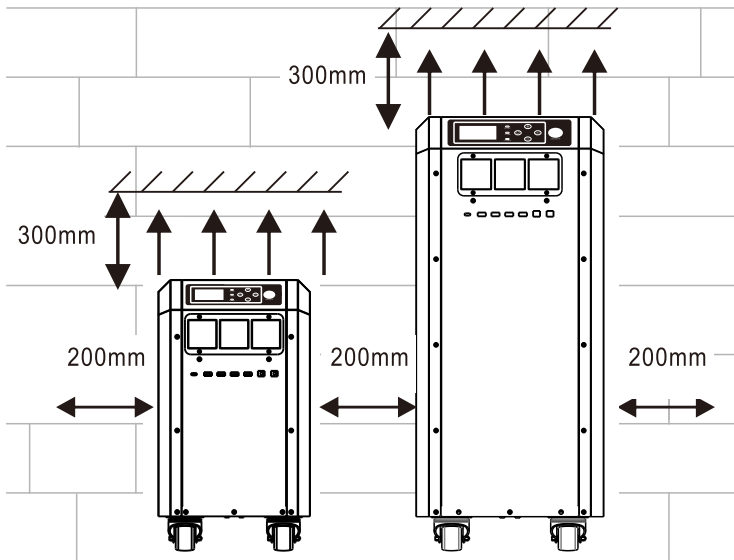

### PV Panel Connection

**CAUTION:** Before connecting to PV modules, please install separately a DC circuit breaker between inverter and PV modules.

**WARNING!** All wiring must be performed by a qualified personnel.

**WARNING!** It's very important for system safety and efficient operation to use appropriate cable for PV module connection. To reduce risk of injury, please use the proper recommended cable size as below.

Model	Typical Amperage	Cable size	Torque Value
3KW DC24V	18A	10AWG	1.2~1.6Nm
2KW DC24V			
1KW DC12V	10A	12AWG	

### PV Panel Selection

When choosing the right PV module, be sure to consider the following parameters:

1. The open-circuit voltage (VOC) of the PV module does not exceed the maximum open-circuit voltage of the PV array of the inverter.
2. The open circuit voltage (VOC) of the PV module should be higher than the minimum value of the cell voltage.
3. The maximum power point voltage of the photovoltaic array should be close to the MPPT optimal working voltage of the inverter or within the MPPT working voltage range. If a photovoltaic module cannot meet this requirement, it is necessary to connect the photovoltaic modules in series to meet the requirements. See the table below.

power	1KW	2KW	3KW
Maximum charging current	60A		
PV open circuit voltage	105VDC	145VDC	145VDC
Photovoltaic MPPT voltage range cut	15-105VDC	30-120VDC	30-120VDC
System battery voltage	12VDC	24VDC	24VDC

Follow the steps below to connect the PV module:

1. Remove the 10mm positive and negative conductor insulating sleeves on the PV inverter.
2. Check that the cable connection between the PV module and the PV input connector is correct. Then, connect the positive (+) side of the cable to the positive (+) side of the PV input connector. Connect the negative (-) of the cable to the negative (-) of the PV input connector.
3. Make sure the wires are securely connected.

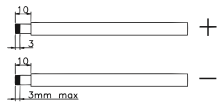



## OPERATION

### Power ON/OFF

The unit could be turned on by simply pressing the ON/OFF switch(located on the front of the case).

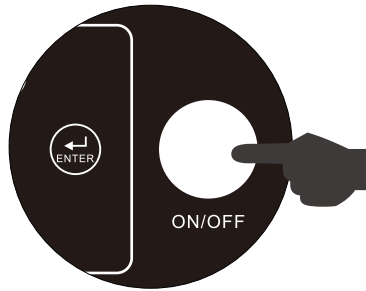

### Operation and Display Panel

The operation and display panel, shown in below chart, is on the front panel of the inverter. It includes three indicators, four function keys and a LCD display, indicating the operating status and input/output power information.

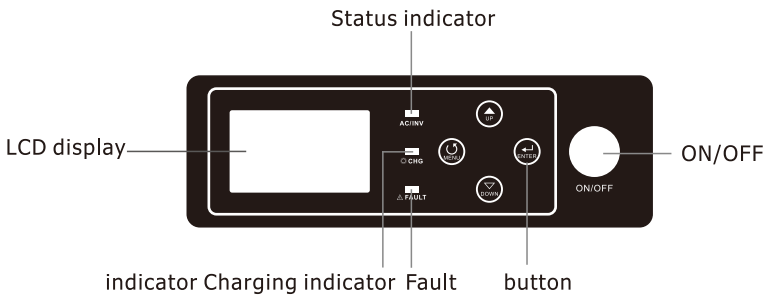

### LED Indicator

LED Indicator		Messages	
AC/INV	Green	Solid On	Output is powered by grid in Line mode.
		Flashing	Output is powered by battery or PV in battery mode.
CHG	Yellow	Flashing	Battery is charging or discharging.
FAULT	Red	Solid On	Fault occurs in the inverter.
		Flashing	Warning condition occurs in the inverter.

### Function Keys

Function Keys	Description
MENU	Enter reset mode or setting mode go to previous selection.
UP	Increase the setting data.
DOWN	Decrease the setting data.
ENTER	Enter setting mode and Confirm the selection in setting mode go to next selection or exit the reset mode.

## LCD Display Icons

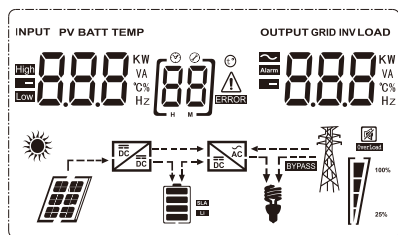

Icon	Function description	
<b>Input Source Information and Output Information</b>		
	Indicates the AC information.	
	Indicates the DC information.	
	Indicate input voltage, input frequency, PV voltage, battery voltage and charger current. Indicate output voltage, output frequency, load in VA, load in Watt and discharging current.	
<b>Configuration Program and Fault Information</b>		
	Indicates the setting programs.	
	Indicates the warning and fault codes. Warning: flashing  with warning code. Fault: lighting  with fault code.	
<b>Battery Information</b>		
	Indicates battery level by 0-24%, 25-49%, 50-74% and 75-100% in battery mode and charging status in line mode.	
In AC mode, it will present battery charging status.		
Status	Battery voltage	LCD Display
Constant	<2V/cell	4 bars will flash in turns.
Current mode / Constant	2 ~ 2.083V/cell	Bottom bar will be on and the other three bars will flash in turns.
Voltage mode	2.083 ~ 2.167V/cell	Bottom two bars will be on and the other two bars will flash in turns.
	> 2.167 V/cell	Bottom three bars will be on and the top bar will flash.
Batteries are fully charged.		4 bars will be on.

In battery mode, it will present battery capacity.		
Load Percentage	Battery Voltage	LCD Display
Load >50%	< 1.717V/cell	
	1.717V/cell ~ 1.8V/cell	
	1.8 ~ 1.883V/cell	
	> 1.883 V/cell	
50% > Load > 20%	< 1.817V/cell	
	1.817V/cell ~ 1.9V/cell	
	1.9 ~ 1.983V/cell	
	> 1.983V/cell	
Load < 20%	< 1.867V/cell	
	1.867V/cell ~ 1.95V/cell	
	1.95 ~ 2.033V/cell	
	> 2.033V/cell	

### Load Information

<b>OVERLOAD</b>	Indicates overload.			
	Indicates the load level by 0-24%, 25-49%, 50-74% and 75-100%.			
	0%~24%	25%~49%	50%~74%	75%~100%

### Mode Operation Information

	Indicates unit connected to the mains.
	Indicates unit connected to the PV panel.
<b>BYPASS</b>	Indicates load is supplied by utility power.
	Indicates the solar charger is working.
	Indicates the DC/AC inverter circuit is working.

### Mute Operation

	Indicates unit alarm is disabled.
--	-----------------------------------

### LCD Setting

After pressing and holding "ENTER" button for 2 seconds, the unit will enter setting mode. Press "UP" or "DOWN" button to select setting programs. And then, press "ENTER" or "MENU" button to confirm the selection and exit.

### Setting Programs

Program	Description	Selectable option
00	Exit setting mode	Escape [00] ESC
01	Output source priority selection	[01] SBU Solar energy provides power to the loads as first priority. If battery voltage has been higher than the setting point in program 21 for 5 minutes, the inverter will turn to battery mode, solar and battery will provide power to the load at the same time. When the battery voltage drops to the setting point in program 20, the inverter will turn to bypass mode, utility provides power to the load only, and the solar will charge the battery at the same time.
		[01] SOL Solar energy provides power to the loads as first priority. If battery voltage has been higher than the setting point in program 21 for 5 minutes, and the solar energy has been available for 5 minutes too, the inverter will turn to battery mode, solar and battery will provide power to the load at the same time. When the battery voltage drops to the setting point in program 20, the inverter will turn to bypass mode, utility provides power to the load only, and the solar will charge the battery at the same time.
		(default) [01] UT Utility will provide power to the loads as first priority. Solar and battery energy will provide power to the loads only when utility power is not available.

02	AC input voltage range	Appliances (default) [02] RPL	If selected, acceptable AC input voltage range will be within 90-280VAC.
		UPS [02] UPS	If selected, acceptable AC input voltage range will be within 170-280VAC.
		VDE [02] VDE	If selected, acceptable AC input voltage range will conform to VDE4105(184VAC-253VAC)
		GEN [02] GEN	When the user uses the device to connect the generator, select the generator mode.
03	Output voltage	[03] 230 <sup>v</sup>	Set the output voltage amplitude, (220VAC-240VAC)
04	Output frequency	50HZ(default) [04] 500	60HZ [04] 600
05	Solar supply priority	[05] BLU	Solar energy provides power to charge battery as first priority
		(default) [05] LBU	Solar energy provides power to the loads as first priority
06	Overload bypass: When enabled, the unit will transfer to line mode if overload occurs in battery mode.	Bypass disable [06] BYD	Bypass enable (default) [06] BYE
07	Auto restart when overload occurs	Restart disable (default) [07] LTD	Restart enable [07] LTE
08	Auto restart when over temperature occurs	Restart disable (default) [08] LTD	Restart enable [08] LTE
10	Charger source priority: To configure charger source priority	If this inverter/charger is working in Line, Standby or Fault mode, charger source can be programmed as below:	
		Solar first [10] CSO	Solar energy will charge battery as first priority. Utility will charge battery only when solar energy is not available.
		Solar and Utility (default) [10] SNU	Solar energy and utility will charge battery at the same time.

		Only Solar [10] 050	Solar energy will be the only charger source no matter utility is available or not.
		If this inverter/charger is working in Battery mode or Power saving mode, only solar energy can charge battery. Solar energy will charge battery if it's available and sufficient.	
11	Maximum charging current: To configure total charging current for solar and utility chargers.(Max. charging current=utility charging current +solar charging current)	60A (default) [11] 60 <sup>A</sup>	Setting range is from 1A to 70A for 1KW models. Increment of each click is 1A.
		80A (default) [11] 80 <sup>A</sup>	Setting range is from 1A to 80A for 2/3KW models. Increment of each click is 1A.
13	Maximum utility charging current	10A (default) for 1kW models [13] 10 <sup>A</sup>	20A (Maximum current) for 1kW models [13] 20 <sup>A</sup>
		20A (default) for 2-3kW models [13] 20 <sup>A</sup>	30A (Maximum current) for 2-3kW models [13] 30 <sup>A</sup>
20	Battery stop discharging voltage when grid is available	11.5V (default) [20] 11.5 <sup>V</sup>	Setting range is from 11.0V to 14.5V for 1kw models. Increment of each click is 0.1V
		23V (default) [20] 23.0 <sup>V</sup>	Setting range is from 22.0V to 29.0V for 2-3kw models. Increment of each click is 0.1V
21	Battery stop charging voltage when grid is available	13.5V (default) [21] 13.5 <sup>V</sup>	Setting range is from 11.0V to 14.5V for 1kw models. Increment of each click is 0.1V
		27.0V (default) [21] 27.0 <sup>V</sup>	Setting range is from 22.0V to 29.0V for 2-3kw models. Increment of each click is 0.1V
22	Auto turn page	(default) [22] PLE	If selected, the display screen will auto turn the display page.
		[22] PLEd	If selected, the display screen will stay at latest screen user finally switches.
23	Backlight control	Backlight on [23] LON	Backlight off(default) [23] LOF

24	Alarm control	Alarm on (default) [24] 600	Alarm off [24] 60F
25	Beeps while primary source is interrupted	Alarm on [25] A00	Alarm off (default) [25] A0F
27	Record Fault code	Record enable (default) [27] F00	Record disable [27] F0F
28	Solar power balance: When enabled, solar input power will be automatically adjusted according to connected load power.	Solar power balance enable [28] 56E	If selected, the solar input power will be automatically adjusted according to the following formula: Max. Input solar power = Max. battery charging power + Connected load power when the machine in OffGrid workstate.
		Solar power balance disable (default) [28] 56d	If selected, the solar input power will be the same to max. Battery charging power no matter how much loads are connected. The max. battery charging power will be based on the setting current in program 11 ( Max. solar power = Max. battery charging power )
29	Power saving mode enable/disable	Saving mode disable (default) [29] 5d5	If disable, no matter connected load is low or high, the on/off status of inverter output will not be effected.
		Saving mode enable [29] 5E7	If enable, the output of inverter will be off when connected load is pretty low or not detected.
30	Battery equalization	Battery equalization [30] E07	Battery equalization disable(default) [30] E05
31	Battery equalization voltage	14.4V (default) [31] E4 144 <sup>v</sup>	Setting range is from 12.0V to 14.5V for 1KW models. Increment of each click is 0.1V
		28.8V (default) [31] E4 288 <sup>v</sup>	Setting range is from 24V to 29.0V for 2-3KW models. Increment of each click is 0.1V























33	Battery equalization time	60min(default) [33] 60	Setting range is from 5 min to 900min. Increment of each clink is 5min.
34	Battery equalization timeout	120min(default) [34] 120	Setting range is from 5 min to 900min. Increment of each clink is 5min.
35	Equalization interval	30days(default) [35] 30d	Setting range is from 0 to 90days. Increment of each clink is 1 day.
36	Equalization activated immediately	Enable [36] REN	Disable(default) [36] Rds
		If equalization function is enabled in program 30, this program can be set up. If "Enable" is selected in this program, it's to activate battery equalization immediately and LCD main page will shows "EQ ". If "Disable" is selected, it will cancel equalization function until next activated equalization time arrives based on program 35 setting. At this time, "EQ " will be shown in LCD main page too.	









After pressing and holding "MENU" button for 6 seconds, the unit will enter reset model. Press "Up" and "DOWN" button to select programs. And then ,press "ENTER" button to exit.

SEt	(default) [dt] nrt	Reset setting disable.
	[dt] r5t	Reset setting enable.















## Fault Reference Code



Fault Code	Fault Event	Icon on
01	Fan is locked when inverter is off	
02	Inverter transformer over temperature	
03	battery voltage is too high	
04	battery voltage is too low	
05	Output short circuited	
06	Inverter output voltage is high	
07	Overload time out	
08	Inverter bus voltage is too high	
09	Bus soft start failed	
11	Main relay failed	
21	Inverter output voltage sensor error	
22	Inverter grid voltage sensor error	
23	Inverter output current sensor error	
24	Inverter grid current sensor error	
25	Inverter load current sensor error	
26	Inverter grid over current error	
27	Inverter radiator over temperature	
31	Solar charger battery voltage class error	
32	Solar charger current sensor error	
33	Solar charger current is uncontrollable	
41	Inverter grid voltage is low	
42	Inverter grid voltage is high	

43	Inverter grid under frequency	
44	Inverter grid over frequency	
51	Inverter over current protection error	
52	Inverter bus voltage is too low	
53	Inverter soft start failed	
55	Over DC voltage in AC output	
56	Battery connection is open	
57	Inverter control current sensor error	
58	Inverter output voltage is too low	

### Warning Indicator

Fault Code	Fault Event	Icon on
61	Fan is locked when inverter is on.	
62	Fan 2 is locked when inverter is on.	
63	Battery is over-charged.	
64	Low battery.	
67	Overload.	
70	Output power derating.	
72	Solar charger stops due to low battery.	
73	Solar charger stops due to high PV voltage.	
74	Solar charger stops due to over load.	
75	Solar charger over temperature.	
76	PV charger communication error.	
77	Parameter error.	

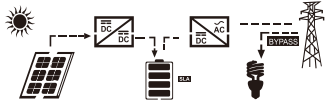
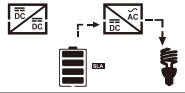
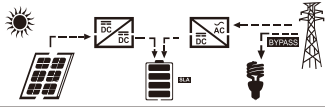
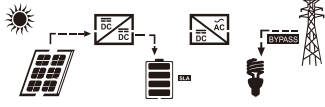
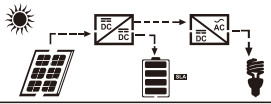
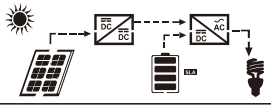
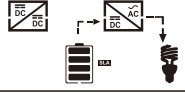
## Operating State Description

Operation state	Description	LCD display
Utility-Tie state	PV energy is charger into the battery and utility provide power to the AC load.	PV is on 
		PV is off 
Charge state	PV energy and grid can charge batteries.	
Bypass state	Error are caused by inside circuit error or external reasons such as over temperature, output short circuited and so on.	
Off-Grid state	The inverter will provide output power from battery and PV power.	Inverter power loads from PV energy 
		Inverter power loads from battery and PV energy 
		Inverter power loads from battery only 
Stop mode	The inverter stop working if you turn off the inverter by the soft key or error has occurred in the condition of no grid.	

## Display Setting

The LCD display information will be switched in turns by pressing "UP" or "DOWN" key. The selectable information is switched as below order: battery voltage, battery current ,inverter voltage, inverter current, grid voltage, grid current, load in Watt, load in VA, grid frequency, inverter frequency, PV voltage, PV charging power, PV charging output voltage, PV charging output current.

Selectable information	LCD display	
Battery voltage/DC discharging current	<sup>BATT</sup> 260 <sup>V</sup>	480 <sup>A</sup>
Inverter output voltage/Inverter output current	229 <sup>V</sup>	<sup>INV</sup> 6.70 <sup>A</sup>
Grid voltage/Grid current	229 <sup>V</sup>	30 <sup>A</sup>
Load in Watt/VA	150 <sup>KW</sup>	<sup>LOAD</sup> 168 <sup>KVA</sup>
Grid frequency/Inverter frequency	<sup>INPUT</sup> 500 <sup>Hz</sup>	<sup>INV</sup> 500 <sup>Hz</sup>
PV voltage and power	<sup>PV</sup> 6.10 <sup>V</sup>	100 <sup>KW</sup>
PV charger output voltage and MPPT charging current	<sup>PV</sup> 250 <sup>V</sup>	<sup>OUTPUT</sup> 400 <sup>A</sup>

## SPECIFICATIONS

MODEL		1012	2024	3024
INVERTER	Rated Power	1KW	2KW	3KW
	surge power	2000VA	4000VA	6000VA
	Waveform	Pure Sine Wave		
	AC Voltage Output	230Vac		
	Rated Battery Input Voltage	12VDC	24VDC	
	Efficiency	90%		
PV Input	Max Charging Current	60A		
	MPPT Tracking Efficiency	98%max		
	Max PV Array Open Circuit Voltage	105VDC	145VDC	145VDC
	PV Array MPPT Voltage Range	15~105VDC	30~120VDC	30~120VDC
AC Input	Rated Input Voltage	230Vac $\pm$ 5%		
	Input Voltage Range	90-280VAC		
	Frequency Range	50Hz / 60Hz		
	Transfer Time	10ms (UPS, VDE); 20ms (APL)		
	AC Charge Current	10/20A ( $\pm$ 4A)	20A/30A ( $\pm$ 4A)	20A/30A ( $\pm$ 4A)
DC Output	USB 5V	4PCS		
	12V	2PCS		
	Type-c	1PCS		
Battery	Battery Type	Lead acid Battery		
	Capacity	100Ah/120Ah/150Ah	100Ah/120Ah/150Ah	100Ah/120Ah/150Ah
	Rated Voltage	12VDC	24VDC	

## TROUBLE SHOOTING

Problem	LCD/LED/Buzzer	Explanation / Possible cause	What to do
Unit shuts down automatically during startup process.	LCD/LEDs and buzzer will be active for 3 seconds and then complete off.	The battery voltage is too low (< 1.91V/Cell)	1. Re-charge battery. 2. Return to repair center.
No response after power on.	No indication.	1. The battery voltage is far too low. (<1.4V/Cell) 2. Battery polarity is connected reversed. Input protector is tripped	1. Check if the battery breaker is ON. 2. Re-charge battery. 3. Return to repair center.
Mains exist but the unit works in battery mode.	Input voltage is displayed as 0 on the LCD and green LED is flashing.	Input protector is tripped	Check if AC breaker is tripped and AC wiring is connected well.
	Green LED is flashing.	Insufficient quality of AC power (Shore or Generator)	1. Check if AC wires are too thin and/or too long. 2. Check if generator (if applied) is working well or if input voltage range setting is correct.(Appliance=>wide)
When the unit is turned on, internal relay is switched on and off repeatedly.	LCD display and LEDs are flashing	Battery is disconnected.	Check if the battery breaker is ON.
Buzzer beeps continuously and red LED is on.	Fault code 07	Overload error. The inverter is overload 110% and time is up.	Reduce the connected load by switching off some equipment.
	Fault code 05	Output short circuited.	Check if wiring is connected well and remove abnormal load.
	Fault code 02	Internal temperature of inverter component is over 90oC.	Check whether the air flow of the unit is blocked or whether the ambient temperature is too high.
	Fault code 03	Battery is over-charged.	Return to repair center.
		The battery voltage is too high.	Check if spec and quantity of batteries are meet requirements.
	Fault code 01	Fan fault	Replace the fan.
	Fault code 06/58	Output abnormal (Inverter voltage below than 202Vac or is higher than 253Vac)	1. Reduce the connected load. 2. Return to repair center
	Fault code 08/09/53/57	Internal components filed.	Return to repair center
	Fault code 51	Over current or surge	Restart the unit, if the error happens again, please return to repair center.
	Fault code 52	Bus voltage is too low	
Fault code 55	Output voltage is unbalanced		
Fault code 56	Battery is not connected well or fuse is burnt.	If the battery is connected well, please return to repair center.	



**MUST**<sup>®</sup>

# GUARANTEE CERTIFICATE

Serial No.: \_\_\_\_\_

Customer's Name				Contact Person	
Address				Telephone No.	
Product/Model:		Post Code		Fax No.	
Date of purchase			Expire Date		
Dealer Signature			Customer Signature		

**MUST**<sup>®</sup>

# GUARANTEE CERTIFICATE

Serial No.: \_\_\_\_\_

Customer's Name				Contact Person	
Address				Telephone No.	
Product/Model:		Post Code		Fax No.	
Date of purchase			Expire Date		
Dealer Signature			Customer Signature		